

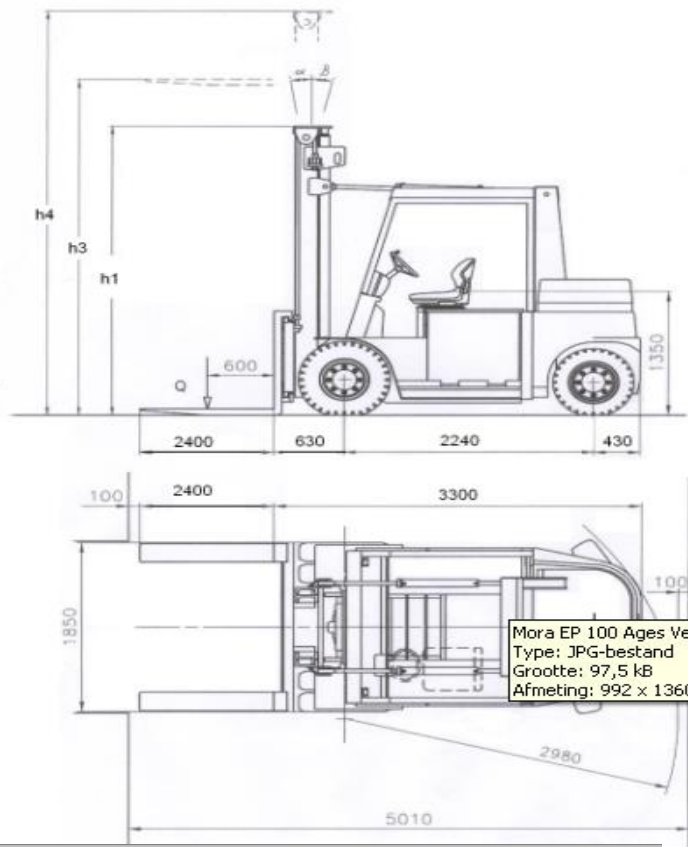

AGES Verhuur B.V.
E1600

verhuur@ages.nl
www.ages.nl
Tel 040-2535555
Fax 084-2289576



Mora EP 100 Ages Verhuur
Type: JPG-bestand
Grootte: 97,5 kB
Afmeting: 992 x 1360 pixels

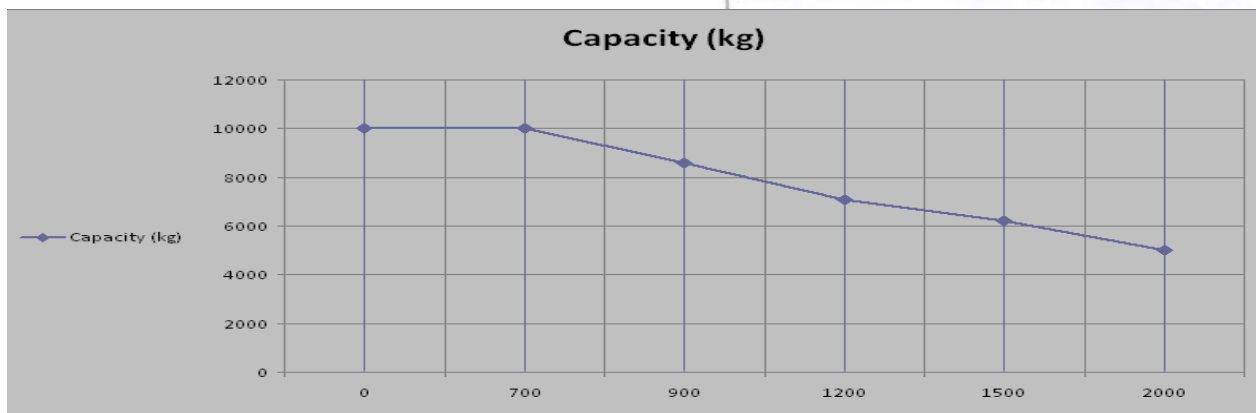

	Merk	Hersteller	Manufacturer	Mora	
1.1	Model	Stapler-Typ	Model	EP 100R	
1.2	Aandrijving	Antrieb	Power	Elektro	
1.3	Capaciteit	Tragfähigkeit / last	Load capacity	10000	Q (kg)
1.5	Lastzwaartepunt	Lastschwerpunkt	Load centre	700	C (mm)
1.6	Eigengewicht	Eigengewicht	Unladen Weight	15.750	kg
2.1	Banden	Bereifung	Tyres	zwart	
3.1	Doorrijhoogte	Hohe Hubgerust eingefahren	Height Mast Lowered	3600	h1 (mm)
4.2	Vrijeheffing	Freihub	Free Lift	2300	h2 (mm)
4.3	Hefhoogte	Hub	Lift Height	7000	h3 (mm)
4.4	Kooihoogte	Horne über Schutzdach	Overhead guard height	2600	h6 (mm)
4.7	Lengte zondervorken	Lange einschl. Gabelrucken	Length to face of forks	3600	l2 (mm)
4.20	Totalebreete	Gesamtbreite	Overall Width	1850	b1 (mm)
4.21	Vorken	Gabelzinkenmabe	Fork Dimensions	70x200x1800	s/e/i (mm)
4.22	Vorkenbord Klasse	Gabeldrager Klasse	Fork carriage Class	4A	
4.23	Vorkenbord brede	Gabeltragerbreite	Fork carriage Width	200	b3 (mm)
3.1	Extra's	Extras	Extra's		
	2 werklampen voor	2 arbeitsscheinwerfer	2 Working lights		
	Banden	Bereifung	Tyres		
	Non-Marking	Nichtkreidend	Non-Marking		
	Zwaailamp	Blitzleuchte	Rotating warning light		
	Side shift	Seitenschieber	Side shift		
	Vorkenversteller	Zinkenverstellung	Fork Positioners		