

Engine powered forklift 1.5 - 3.5 ton

TONERO



Engine powered forklift 3.5 ton

Truck specifications					02-8FGJF35	02-8FDJF35	52-8FDJF35
Identification	1.1	Manufacturer			TOYOTA	TOYOTA	TOYOTA
	1.2	Model			02-8FGJF35	02-8FDJF35	52-8FDJF35
	1.3	Drive			LPG	Diesel	Diesel
	1.4	Operator type			Rider seated	Rider seated	Rider seated
	1.5	Load capacity/rated load	Q	kg	3500	3500	3500
	1.6	Load centre	c	mm	500	500	500
	1.8	Load distance, centre of drive axle to fork	x	mm	495	495	495
	1.9	Wheelbase	y	mm	1700	1700	1700
	Weight	2.1	Service weight		kg	4820	4860
2.2		Axle load, with load, front/rear		kg	7250/1070	7260/1100	7280/1110
2.3		Axle load, without load, front/rear		kg	1690/3130	1710/3150	1720/3170
Tyres	3.1	Tyre - pneumatic (P), pneumatic shaped cushion (SE), solid rubber (R)			SE	SE	SE
	3.2	Tyre size, front			250 - 15	250 - 15	250 - 15
	3.3	Tyre size, rear			6.50 - 10	6.50 - 10	6.50 - 10
	3.5	Wheels, number front/rear (x = driven wheels)			2x2	2x2	2x2
	3.6	Track width, front	b ₁₀	mm	1060	1060	1060
	3.7	Track width, rear	b ₁₁	mm	965	965	965
	Dimensions	4.1	Tilt of mast/fork carriage forward/backward		α/β	deg	6/11
4.2		Height, mast lowered		h ₁	mm	2115	2115
4.3		Free lift		h ₂	mm	135	135
4.4		Lift		h ₃	mm	2955	2955
		Lift height		h ₂₃	mm	3000	3000
4.5		Height, mast extended		h ₄	mm	4260	4260
4.7		Height of overhead guard (cab)		h ₆	mm	2180	2180
4.8		Seat height		h ₇	mm	1120	1120
4.12		Coupling height		h ₁₀	mm	335	335
4.19		Overall length		l ₁	mm	3850	3850
4.20		Length to face of forks		l ₂	mm	2850	2850
4.21		Overall width		b ₁	mm	1290	1290
4.22		Fork dimensions		s/e/l	mm	45/125/1000	45/125/1000
4.23		Fork carriage DIN 15 173, class/type A, B				IIIA	IIIA
4.24		Fork-carriage width		b ₃	mm	1070	1070
4.31		Ground clearance, with load, below mast		m ₁	mm	130	130
4.32		Ground clearance, centre of wheelbase		m ₂	mm	190	190
4.33		Aisle width for pallets 1000x1200 crossways		A _{st}	mm	4185	4185
4.34	Aisle width for pallets 800x1200 lengthways		A _{st}	mm	4385	4385	
4.35	Turning radius		W _a	mm	2490	2490	
4.36	Internal turning radius		b ₁₃	mm	745	745	
Performance data	5.1	Travel speed, with/without load			km/h	19,0/19,5	16,5/17,0
	5.2	Lift speed, with/without load			m/s	0,43/0,45	0,37/0,40
	5.3	Lowering speed, with/without load			m/s	0,50/0,45	0,50/0,45
	5.6	Max. drawbar pull, with/without load			N	17000/10500	17100/10600
	5.7	Gradeability, with load ¹⁾²⁾			%	18	19
	5.8	Max. gradeability, with/without load ²⁾			%	20/18	21/19
	5.10	Service brake				Hydraulic	Hydraulic
Combustion engine	7.1	Engine manufacturer/type				Toyota 4Y-ECS	Toyota 1DZ-III (IIIA)
	7.2	Engine power according to ISO 1585			kW	42	36
	7.3	Rated speed			1/min	2570	2400
	7.4	No. of cylinders/displacement			cm ³	4/2237	4/2486
	7.5a	Fuel consumption according to VDI 60			l/h	—	4,9
	7.5b	Fuel consumption according to VDI 60			kg/h	3,8	—
Others	8.2	Operating pressure for attachments			bar	147	147
	8.3	Oil volume for attachments			l/min	65 - 74	65 - 80
	8.4	Sound level at the driver's ear according to EN 12 053			dB(A)	77	79

¹⁾ At 1,5 km/h

²⁾ Computed val

Performance data and dimensions are nominal and subject to tolerances.

Specifications are subject to change without notice.

Please obtain the latest specifications before contracting products.

Mast dimensions and rated capacities

Model		V										FV					FSV						
8FG/DJF35	Lift height	h_{23}	3000	3300	3500	3700	4000	4500	5000	5500	6000	3000	3300	3500	3700	4000	4300	4700	5000	5500	6000	6500	7000
	Lift	h_3	2955	3255	3455	3655	3955	4455	4955	5455	5955	2955	3255	3455	3655	3955	4255	4655	4955	5455	5955	6455	6955
	Height, mast lowered	h_1	2115	2295	2395	2495	2745	2995	3245	3545	3795	2115	2295	2395	2495	2745	2230	2435	2625	2875	3125	3375	3625
	Height, mast extended ¹⁾	h_4	3910	4210	4410	4610	4910	5410	5910	6410	6910	3765	4065	4265	4465	4765	5065	5465	5765	6265	6765	7265	7765
	Height, mast extended ²⁾	h_4	4260	4560	4760	4960	5260	5760	6260	6760	7260	4250	4550	4750	4950	5250	5550	5950	6250	6750	7250	7750	8250
	Free lift, without load backrest	h_2	135	135	135	135	135	135	135	135	135	1390	1570	1670	1770	2020	1500	1710	1900	2150	2400	2650	2900
	Free lift, with load backrest	h_2	135	135	135	135	135	135	135	135	135	[1290]	[1470]	[1570]	[1670]	[1920]	1015	1225	1415	1665	1915	2165	2415

1) Without load backrest

2) With load backrest; Height of standard load backrest is 1220 mm.

Data in [] are for when "A4 piping" is selected.

Single tyre		V										FV					FSV						
8FG/DJF35	Tilt range, forward	deg	6	6	6	6	6	6	6	—	—	6	6	6	6	6	6	6	6	6	6	6	—
	Tilt range, backward	deg	11(6)	11(6)	11(6)	11(6)	11(6)	6	6	—	—	11(6)	11(6)	11(6)	11(6)	11(6)	6	6	6	6	6	6	—
	Load capacity, P tyres at 500 mm LC	kg	3500	3500	3500	3500	3500	3500	3300	—	—	3500	3500	3500	3500	3500	3500	3400	3300	2700	2000	1100	—
	Load capacity, SE tyres at 500 mm LC	kg	3500	3500	3500	3500	3500	3500	3400	—	—	3500	3500	3500	3500	3500	3500	3400	3300	2850	2150	1100	—

Dual tyre		V										FV					FSV						
8FG/DJF35	Tilt range, forward	deg	6	6	6	6	6	6	6	6	6	6	6	6	6	6	6	6	6	6	6	6	6
	Tilt range, backward	deg	11(6)	11(6)	11(6)	11(6)	11(6)	11(6)	6	6	6	11(6)	11(6)	11(6)	11(6)	11(6)	6	6	6	6	6	6	6
	Load capacity, P tyres at 500 mm LC	kg	3500	3500	3500	3500	3500	3500	3400	2950	1900	3500	3500	3500	3500	3500	3500	3400	3300	3200	2400	1650	900

Data in () are for when "Cabin Series" is selected (minimum front windshield).

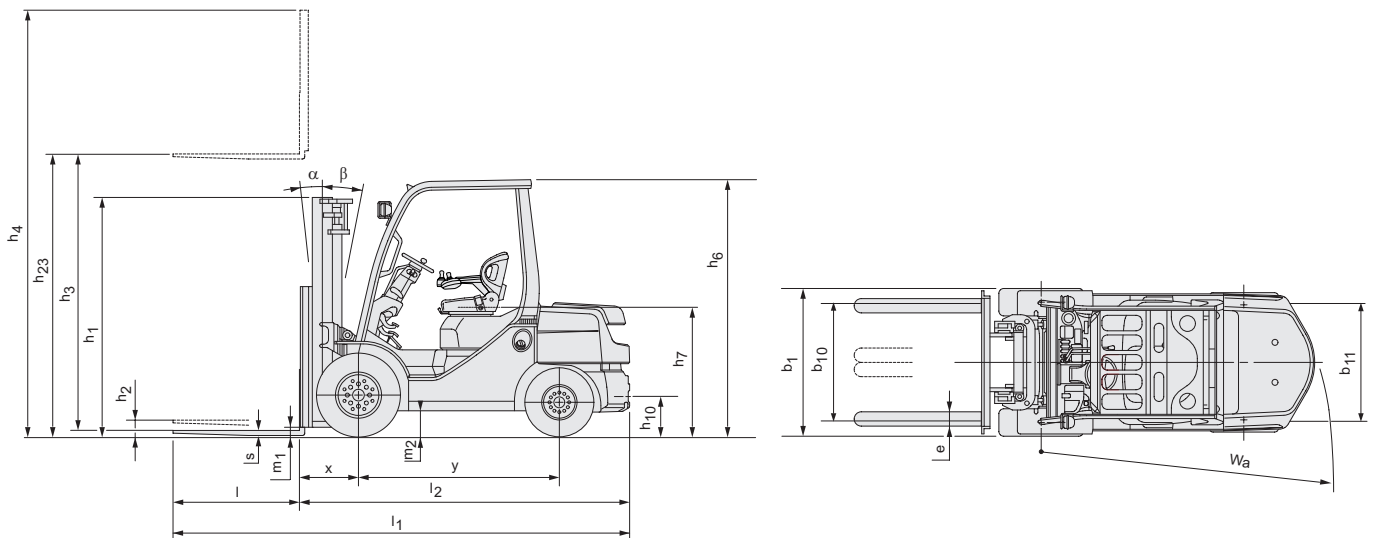

Standard equipments:

- Toyota SAS (System of Active Stability*)
- Toyota OPS (Operator Presence Sensing)
- Toyota ORS seat (Operator Restraint System)
- Wide visible mast (V3000 mm)
- Load backrest (Height: 1220 mm)
- Long forks (Length: 1000 mm)
- Long forkbar [Length: 920 mm (8FG/DF15.18); 1020 mm (8FG/DKF20, 8FG/ DF20.25); 1070 mm (8FG/DF30,8FG/DJF35)]
- 3-way valve (A400)
- Dual brake system
- Pneumatic shaped cushion tyres
- Full hydraulic power steering
- 7" cyclone air cleaner with snorkel air intake
- Anti-restart ignition key switch
- Long life coolant 50%
- Headlights
- Rear combination lights
- Combination meter including self diagnostic system
- Adjustable tilt steering column
- Polycarbonate roof
- Tilt cylinder boots (STD on 1ZS engine only)

* = When dual tyres are selected, the Active Control Rear Stabilizer function of the SAS system of Active Stability (SAS) is not included.



TP-Technical Publications, Sweden — 745562-040, version 8, 2017-08-03